

# MEDALLION PROFESSIONAL

## 17" WIDE OPEN BURNER RANGE

### STANDARD FEATURES

- Stainless steel front and sides STANDARD
- 6" (152mm) chrome steel adjustable legs
- Adjustable stainless steel front rail 6-1/16" (154mm) to 7-5/8" (194mm)
- Two (2), 37,000 BTU (10.8 kW), "Lift-Off" burners
- Removable cast-iron grates over each burner
- One single fully protected standing pilot covering each front and rear burner section
- 1-1/4" NPT front manifold
- One-piece aluminized steel drip tray covering both burners
- Storage base interior is aluminized steel
- One year limited parts & labor warranty (USA and Canada only)

### OPTIONAL FEATURES

- Stainless steel back rear panel
- Stainless steel common front rail up to 68" (1728mm) wide, (No additional charge)
- Rear gas connection, 3/4" or 1" NPT
- End caps and cover (no charge)- Must specify
- Polyurethane non-marking swivel casters (2) w/front brakes
- Storage base shelf-aluminized or stainless steel
- Single deck stainless steel high shelf
- Double deck stainless steel high shelf
- 10" (254 mm), 17" (432mm) 22.375" (568mm) 34.375" (873mm) high stainless steel backguard
- Stainless steel vertical flue riser, 13"W x 34.375"H, (330mm x 873mm)

# AMERICAN RANGE

CHEF INSPIRED, PROFESSIONAL COOKING EQUIPMENT



Optimized Engineering



**Model Shown HD17-2-0**  
Shown with optional background



Optimized Engineering

### SHORT FORM SPECIFICATIONS:

The Medallion Professional O.E. (Optimized Engineering) Heavy-Duty Series by American Range is the crème de la crème in commercial cooking equipment. Designed for the professional chef in high demanding/continuous use operations. Our Medallion Professional O.E. Series offers advanced innovation and technology to deliver unprecedented cooking performance and experience.

Model: **HD17-2-0**, Heavy-Duty Medallion Professional O.E. Series, gas powered **17" Two Burner Attachment with Storage Base**. Storage base to include removable hinged door. Includes stainless steel front and sides with 6" chrome legs (unless otherwise specified). Two (2) **Power-Max** 37,000 Btu/hr each Lift-Off cast iron burners. Heavy-duty cast iron grate per burner section. Unit to be 17" (432mm) wide and 38" (965mm) deep with telescoping front rail fully extended to a maximum of 7-5/8" (194mm). Specify Natural gas (NG) or Liquid Propane gas (LP). ETL listed. Also available as a Modular Top-Model: HD17-2-M.

## 17" WIDE OPEN BURNER RANGE

Attachment with storage base, or as modular top  
HD17-2-0, HD17-2-M

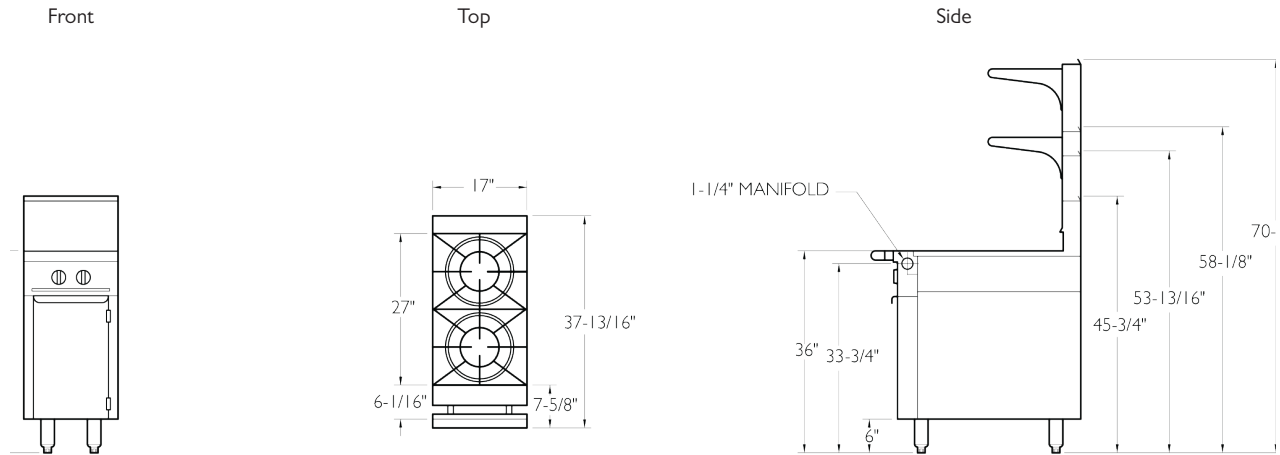

### EXTERIOR DIMENSIONS

Model#	HD17-2-0	HD17-2-M
Width	17"/432mm	17"/432mm
Depth	38"/965mm (Rail out Dim)	38"/965mm
Height w/NSF legs	36"/914mm	36"/914mm(w/stand)
Height Less NSF Legs	30"/762mm	8"/203mm (less stand)

### STORAGE BASE INTERIOR

Width	14"/356mm	N/A
Depth	30"/762mm	N/A
Height	20"/508mm	N/A
Weight (LB/KG)	215/98 N/A	105/48

INPUT-Btu/hr (N-Gas)	HD17-2-0	KW Eq	HD17-2-M	kW Equivalent
O/T Burner	74,000	21.69	74,000	21.69
(37,000BTU/ea)	74,000	21.69	74,000	21.69
TOTAL				—

I = Oven / C = Convection Oven (30,000BTU/ea) / 0 = Storage Base / M = Modular Top

#### Installation Notes:

Combustible Wall Clearances

Sides: 6" (152mm)

Back: 6" (152mm)

For reduced clearances, refer to ANSI Z223.1/NFPA #54 and CAN/CGA B149.

#### Entry Clearance:

Crated: 22 1/4" (565mm)

Uncrated: 17 1/4" (438mm)

#### Manifold Pressure:

Natural 6 W.C. (15 mbar)

Propane 10 W.C. (25 mbar)

NOTE: Data applies only to North America.

Gas Input Ratings shown here are for installations up to 2,000 ft. (610m) above sea level. Specify altitudes over 2,000 ft.

Gas Input Ratings shown here are for installations up to 2,000 ft. (610m) above sea level. Specify altitudes over 2,000 ft.

Commercial cooking equipment requires an adequate ventilation system. For additional information, refer to the National Fire Protection Association's standard NFPA96 "Vapor Removal from Cooking Equipment." (NOTE: For North America only)

Please specify gas type when ordering.



Because of continuing product improvement these specifications are subject to change without notice.